

Automatic Transfer Switches (ATS)

Mains - Standby Supply Automatic Transfer Switches

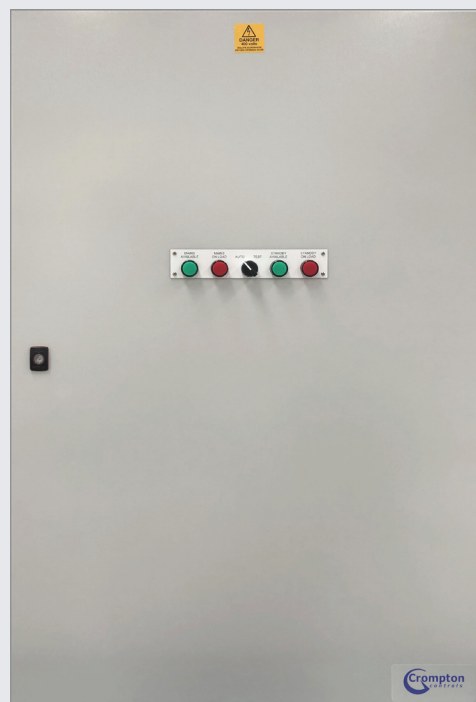

- Single Phase ATS
- Mechanically & Electrically interlocked contactors
- AC1 rated contactors to BS EN 60947-6-1
- Removeable top and bottom gland plates
- IP65 Enclosure
- Auto / Manual test switch
- Designed for Mains - Generator or Mains - Mains
- Two wire generator start
- Configurable timers
- Panel status LED indicators
- Custom designs available



REFERENCE	DESCRIPTION	ENCLOSURE SIZE
CCATS40A1PHM-S	CCLTD 40A AUTOMATIC TRANSFER SW 1PH 230V	400 x 400 x 210mm
CCATS60A1PHM-S	CCLTD 60A AUTOMATIC TRANSFER SW 1PH 230V	500 x 400 x 210mm
CCATS125A1PHM-S	CCLTD 125A AUTOMATIC TRANSFER SW 1PH 230V	600 x 400 x 210mm
CCATS160A1PHM-S	CCLTD 160A AUTOMATIC TRANSFER SW 1PH 230V	800 x 600 x 300mm
CCATS200A1PHM-S	CCLTD 200A AUTOMATIC TRANSFER SW 1PH 230V	800 x 600 x 300mm

Available in sizes above 200A, please contact us for details.
Custom designs also available.



(ATS) Automatic Transfer Switches

DESCRIPTION & FUNCTION

A range of ATS panels to be used where the local Mains (primary) supply is backed up by a generating* set or secondary power supply. The ATS panel monitors the local Mains supply and will switch to the secondary if this should fail or fall outside pre-set limits. The ATS panel controls the switching of the load from the Mains supply to the standby supply. On return of the Mains supply the ATS panel will monitor it to ensure it is stable and then transfer the load from the standby back to the Mains supply. If the secondary supply is a generator, at this point the ATS panel will request the generator to stop.

A phase failure relay is used for Mains voltage monitoring and offers under and over voltage protection as well as phase sequence. The panel uses two timer relays to control timing functions in the panel. Timer one is used to control the Mains restoration period, this controls the period the Mains supply has to be healthy before engaging the Mains contactor. Timer two controls the standby settling period, this timer is useful for situations when the standby supply is a generator as it ensures the generator has ran up to speed and stabilized before a load is applied to the generator.

The default setting for the primary Mains restoration period is one minute and timer two is set for 15 seconds. (Both are fully adjustable). The generator start signal is by means of volt free normally open (N/O) contact closing when the generator is required to run. A two position on selector switch is used for control. In the AUTO position on all operations are automatic with the panel switching to the standby supply when there is a failure of the primary Mains supply. The second position - TEST - switches the load to the secondary supply (The start signal is given to the generator).

Cable entry as standard is arranged for bottom entry with a direct connection into the contactors. A 16A auxiliary output is provided for use with battery chargers, water jacket heaters etc.

The Timers inside the panel are adjustable to suit the required start up and rundown times.

*The Generator is required to have a 2 wire start / Auto start facility

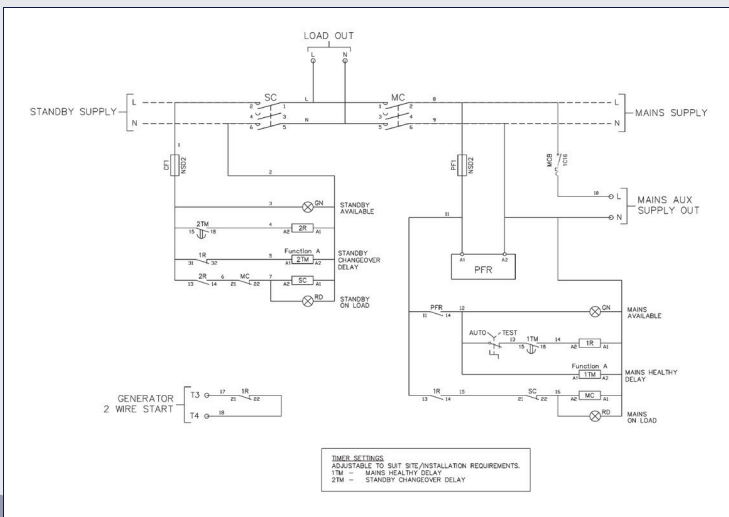

Generic ATS Schematic Diagram

